

VESTEL

CORPORATE PRESENTATION





VESTEL



Consumer
Electronics



Home
Appliances



Visual Solutions



Electric Vehicle
Charger



 **1.163.000 m²**
Общая площадь
территории
завода

 **18,500**
Сотрудников

 **№1 место по
экспорту из
Турции
бытовой
техники с
объемом
более
\$ 2,5
миллиарда**

VESTEL



 **30 Миллионов
штук – объем
производства всех
заводов**

 **15 Миллионов –
объем
производства ТВ**

**13.5 Миллионов –
объем
производства КБТ**

 **\$ 3,2 Миллиарда –
Годовой оборот
компании**

VESTEL

Конкурентные преимущества



Огромный опыт работы с
А брендами

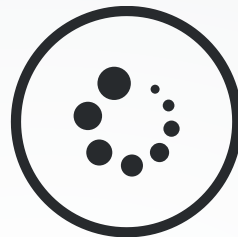

900+ клиентов
500+ брендов

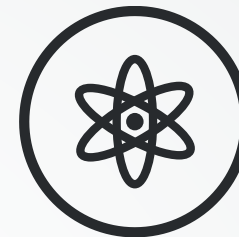

Инновационный
дизайн



Короткий срок
производства



Географическая доступность
в Европу, Россию



Наши офисы и филиалы

Vestel Trade
Vestel France
Vestel Germany
Vestel Iberia
Vestel UK
Vestel Holland

Vestel CIS
Vestel Romania
Vestel Central Asia
Vestel Poland
Vestel Gulf
Vestel China
Vestel Vietnam
Vestel USA Inc.



VESTEL



Доля Vestel в мировом производстве

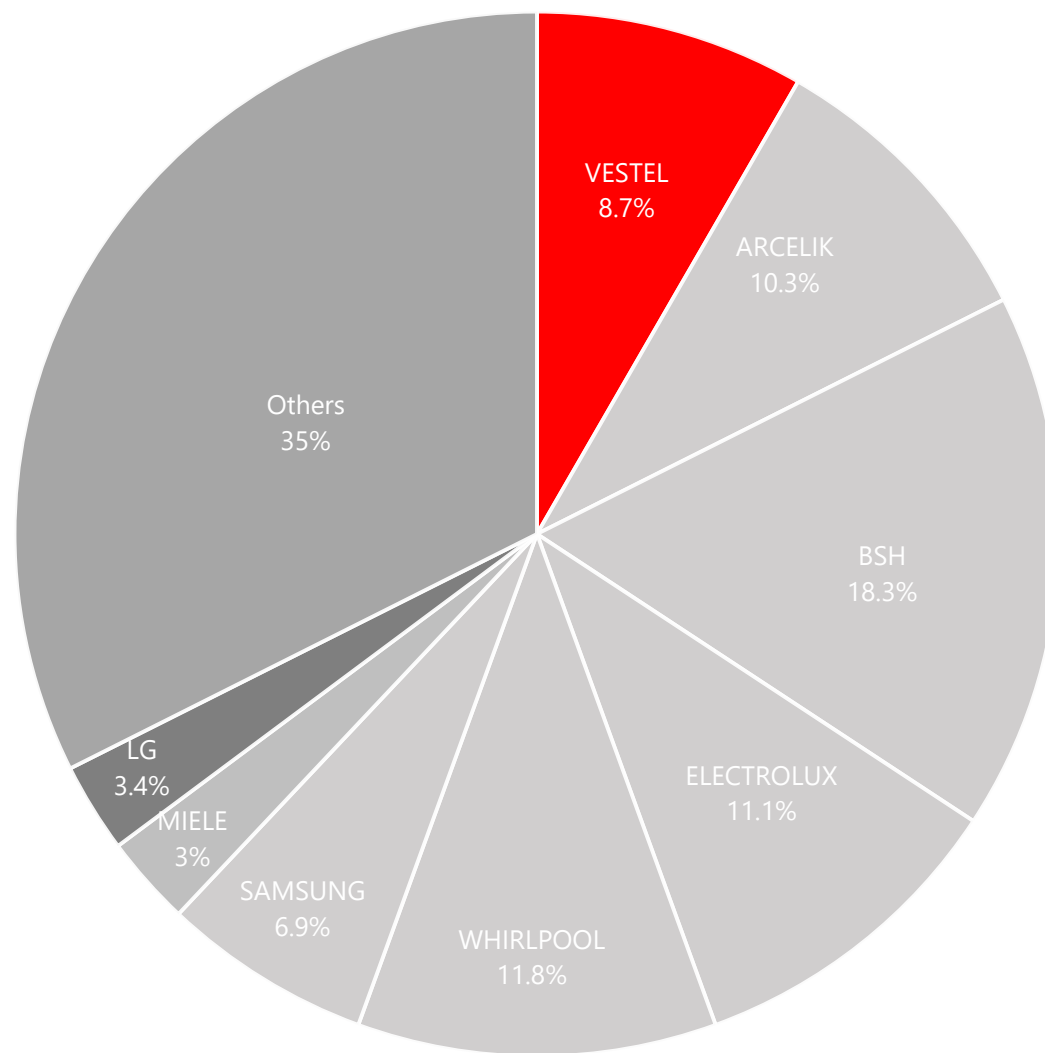

Links



[Видео о заводе](#)



[Видео о заводе от National Geographic](#)



Best R&D of Turkey 2019

Vestel Electronics has been selected as Best R&D of Turkey by Ministry of Industry and Technology among biggest companies of the country in 7th Technology Development Areas and R&D Centers Award.



The Best Invention – WEWALK 2019

WeWalk, a smarter cane that has been developed by VESTEL and Young Guru Academy together has been selected as Best Invention of 2019 in the accessibility category by TIME.

Международные награды



Sustainable Business Award 2019

As one of the companies of Zorlu, Korteks were awarded for its 'Effective Use of Water in Industry' project in the 'Water Management' category, within the 'Sustainable Business Awards 2019'.

Международные награды



CES Innovation Awards 2019
In Home Appliances category, Vestel received 'CES 2019 Innovation Awards HONOREE' for Vestel Smart Fridge with VacuumBag and Fermentstore technology.





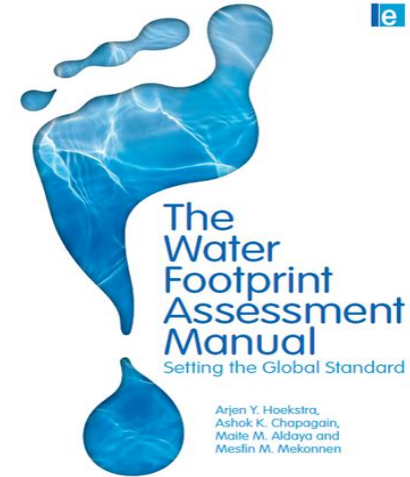

























































The Low Carbon Heroes Award 2018
Given by the Society for Sustainable Production and Consumption (SPCA)



The Water Footprint Certificate 2017
The first company in Turkey received 'The Water Footprint' certificate for its Water Management studies and environmental sustainability of water use in White Goods sector.

Vestel White Goods Design Awards (2008-2021)

2008-2010	2011	2012	2013	2014	2015	2016	2017	2018	2019	2020	2021
 reddot design award 2 Red Dot Awards	 reddot design award 1 Red Dot Awards	 2012 Good Design Award 7 Design Turkey Good Design Award	 reddot design award 2 Red Dot Awards	 reddot design award 1 Red Dot Awards	 reddot design award 1 Red Dot Awards	 reddot design award A Red Dot Awards	 product design award 2 If Design Awards	 Superior Design Award 2 Design Turkey Superior Award	 Plus X Awards Most Innovative Brand	 reddot design award 3 Red Dot Awards	 19 Plus X Awards
 4 Plus X Awards	 35 Plus X Awards	 Superior Design Award 1 Design Turkey Superior Award	 18 Plus X Awards	 Plus X Awards Best Brand Of The Year	 17 Plus X Awards	 product design award 2 If Design Awards	 Good Design Award 3 Design Turkey Good Design Award	 Good Design Award 3 Design Turkey Good Design Award	 1 Ces Innovation Award	 5 Good Design Awards	 6 International Design Awards
 product design award 2 If Design Awards	 6 German Design Award Nominee	 reddot design award 4 Red Dot Awards	 product design award 3 If Design Awards	 Turquality Award	 10 Plus X Awards	 Good Design Award 3 Design Turkey Good Design Award	 product design award 6 Good Design Awards	 6 Good Design Awards	 product design award 3 If Design Awards	 5 Good Design Awards	 6 International Design Awards
 Superior Design Award 1 Design Turkey Superior Award	 5 Good Design Awards	 32 Plus X Awards	 product design award 1 If Design Awards	 product design award 2 If Design Awards	 Good Design Award 3 Design Turkey Good Design Award	 Best Product Of The Year Plus X Awards Best Product Of The Year	 Best Product Of The Year Plus X Awards Best Product Of The Year	 6 Good Design Awards	 32 Plus X Awards	 5 Good Design Awards	 6 International Design Awards
 Good Design Award 3 Design Turkey Good Design Award	 product design award 3 If Design Awards	 Most Innovative Brand Plus X Awards Most Innovative Brand	 Best Product Of The Year Plus X Awards Best Product Of The Year	 5 Good Design Awards	 Best Product Of The Year Plus X Awards Best Product Of The Year	 3 Design Turkey Good Design Award	 6 Good Design Awards	 4 Plus X Awards Best Product Of The Year	 5 Good Design Awards	 6 International Design Awards	 6 International Design Awards

Total by category
298 design awards

Vestel Brown Goods Design Awards (2006-2021)

2006-2010



1 ETMK Design Award



9 Good Design Awards



8 Design Turkey Awards



3 Red Dot Awards



4 Spark Design Awards



9 Plus X Awards

2011



7 Good Design Awards



4 Plus X Awards



1 Plus X Awards

2012



9 Good Design Awards



2 Design Turkey Awards



1 Red Dot Award



27 Plus X Awards



1 A Design Award



12 German Design Prize

2013



10 Good Design Awards



1 Red Dot Awards



35 Plus X Awards



8 A Design Award



1 If Design Award



4 German Design Prize

2014



4 Good Design Awards



3 Design Turkey Awards



25 Plus X Awards



10 A Design Award

2015



9 Good Design Awards



21 Plus X Awards



5 A Design Award

2016



1 Good Design Award



4 Design Turkey Awards



33 Plus X Awards



5 A Design Award



1 If Design Award

2018



6 Good Design Award



2 Design Turkey Awards



2 Red Dot Award



19 Plus X Awards

2019



26 Plus X Awards



1 A Design Award

2020



1 If Design Awards



reddot design award

2 Red Dot Awards



6 Good Design Awards



11 International Design Awards

2021



25 Plus X Awards



1 Plus X Awards
Most innovative brand of the year

Total by category
431 design awards

VESTEL

Vestel Экспорт



Экспорт в 158 стран мира

Europe
CIS and Baltic Countries
Middle East
Africa
America
Australia
Asia



TOSHIBA HITACHI

JVC

LOEWE.

Panasonic

TELEFUNKEN

NOKIA

Cdiscount



Systeme **U**

BUT



TESCO

expert



Carrefour

ASDA



E.Leclerc

EP:
ElectronicPartner

RTV EURO AGD



MEDION

Media Markt



EURONICS

real



John Lewis



Dixons

boulanger

Auchan

TechniSat



Harvey Norman



Наши
партнеры

SHARP

HITACHI

Panasonic

HYUNDAI

ATAG



B/S/H/

gorenje

Brandt

GRAM



IFB

KENWOOD



Cylinda



Haier



RANGEMaster

DAEWOO

CANDY



Rinnai

Paloma

Наши
партнеры

Наши продукты

ТВ

Холодильники

Коммерческие дисплеи

Стиральные машины

Сушильные машины

Посудомоечные машины

Зарядные устройства для электромобилей

Встраиваемые кухонная техника

Система «Умный Дом»

Кондиционеры

Водонагреватели

Холодильники



Multi Door линейка



Double Compressor & Double Multi Zone
14 Variationvin 1 FridgeVitaStore
Compartment with Smart Fan Tech.
Cold Wrap Cooling & Cold Jet Cooling
Safe Close Chiller
Motion Sensor
Night Sensor
Safe Close Mullion Bar Technology
Indirect Interior Lighting



Cold Wrap Cooling & Cold Jet Cooling
6 mm tempered glass shelves
Safe Close Chiller
Night Sensor
Safe Close Mullion Bar Technology
Indirect Interior Lighting
Frameless Touch Display



3 Different Temperature Zone
6 mm tempered glass shelves
Glass oven tray
Wineshelf with rails
Automatic Ice-maker
Water Filter
Multi LED Illumination

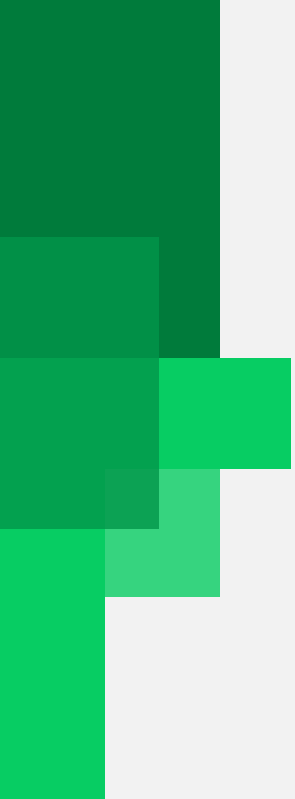

Решения для хранения продуктов



VACUUM BAG

Keep Fresh up to the Last Part

Vacuum method could prevent oxygen to touch the food providing longer freshness. You can easily vacuum your residue foods and so keep them fresh and healthy. This feature is easy to use and also easily accessible.

Vacuum Bag technology prolongs the storage life of deli products up to 8 times



VESTEL

84cm Two Door Top Mounted range offers higher energy efficiency, more stylish design, larger interior volume and user friendly solutions. Also it comes with No Frost Multi Cooling technology.



643
84x186cm



653
84x186cm

Широкие
ХОЛОДИЛЬНИКИ
84 см

(643– 653)

VESTEL

70&76cm Bottom Mounted range offers higher energy efficiency, more stylish design, larger interior volume and user friendly solutions. Also it comes with No Frost Multi Cooling technology.



462
70x173cm



492
70x192cm



553
76x186cm

Холодильники
70-76 см

(462-492-553)

VESTEL

70cm Two Door Top Mounted range offers higher energy efficiency, more stylish design, larger interior volume and user friendly solutions. Also it comes with No Frost Multi Cooling technology.



463
70x173cm



473
70x183cm



483
70x287cm

Холодильники
70 см

(463 – 473 – 483)

VESTEL

60cm combi product range is completing the missing part of the whole combi range. These models are working by using No Frost Multi Cooling Technology besides, they can offer almost all optional features that we have.



373
60x185cm
60/40 door split



353
60x185cm
50/50 door split



383
60x201cm
65/35 door split

Холодильники
60 см

VESTEL

NoFrost MultiCoolingSystem



"No Frost MultiCooling System provides extra freshness with optimum humidity levels in each independent compartment, prevents odour mixing and keeps flavour of foods"



Odour Free



Longer Freshness



Технология
охлаждения –
Nofrost
Multi Cooling

Main advantages of the NoFrost Multi Cooling system;

Two separate cooling systems

Stops food from drying out

No odour transfer between the fridge and
the freezer

Increased humidity in the fridge
compartment for extra freshness



New NoFrost
System



Conventional
System



Foldable glass shelf

Optional for Refrigerator Compartment



Normal Position



Folded

The below shelf height doubles, only with a push.

Twice as high objects can be stored.

Up & Down



Either maximize the bottle shelf, for higher bottles, or reduce it to save space for the dairy shelf.

It can be set to 6 different positions with a handy mechanism.



Adjustable door rack

Optional for Larder Model

Решения для хранения



When the door is 90° open:

- Fully accessible inside
- The Crispers, Chiller and Freezer Boxes are easily detachable
- Zero-clearance between door and the adjacent wall, no bumping/cracking of doors



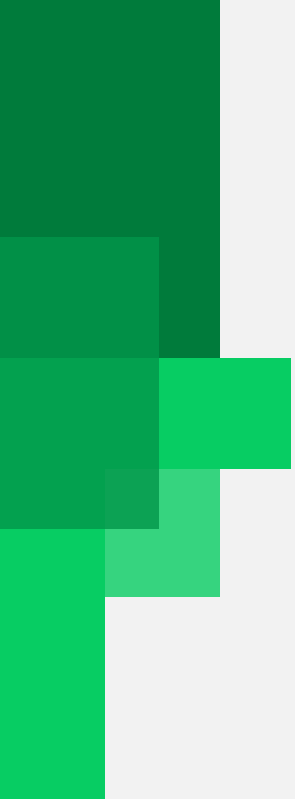

Natural Ion Tech

Увеличивает срок хранения еды в 2 раза



Maxi Fresh Preserver

Увеличивает срок свежести фруктов и овощей



CrystaLight

УФ фильтр для уменьшения неприятного запаха внутри холодильника

Решения для здоровой еды



TEST REPORT

Address: 10-20, Pothohi-gil, Chongno-gu, Seoul, Korea
 TEL: 82-2-377-0000 FAX: 82-2-377-0001 E-MAIL: www.tae-sung.com

Applicant: customer ID: 2020-0000-0001 Date of Sample: 2020.06.19
 Applicant's name: Taesung Korea Place of Test: 2020.06.19 ~ 2020.07.01
 Applicant's address: 171-11, Seongbuk-ro, Seongbuk-gu, Seoul, Korea Test Report: 2020-0000-0001
 Sample name: 1. Maxi Fresh Preserver (Sample) 2. Ultra Pure UV Filter (Sample)
 Sample amount: 1. 10PCS (10PCS/10PCS) 2. 1PCS (1PCS/1PCS)
 Testing Environment: Temp: 17.1, 8.3, 28.3 (20-25) Standard

Substance	Unit	Result		Test Method
		1st	2nd	
1. Maxi Fresh Preserver	Concentration (ppm)	1.00	0.01	K18-10001-01 (2020)
	Concentration (ppm)	0.01	0.01	

Note: 1. This is certified that the above content is available for use in the report and will be provided in the report.
 2. Sample and testing results are subject to product, method and standard and cannot be used as a reference for other products.
 3. This report is issued only for the purpose of the test and is not intended to be used as a reference for other products.
 4. This test is for the test result only and is not intended to be used as a reference for other products.

Allocation: Operator: CHANG-SUNG KIM, Director: TAE SUNG KIM, Date: 2020.06.19

TAE SUNG ENVIRONMENTAL INSTITUTE DIRECTOR

Page 1 of 1 (2/2)



Стиральные машины





Прямая подача воды через цикла стирки. Уменьшает расход воды, энергии и экономит деньги.

VESTEL

25 циклов
БЕСПЛАТНО на
каждые 100
циклов

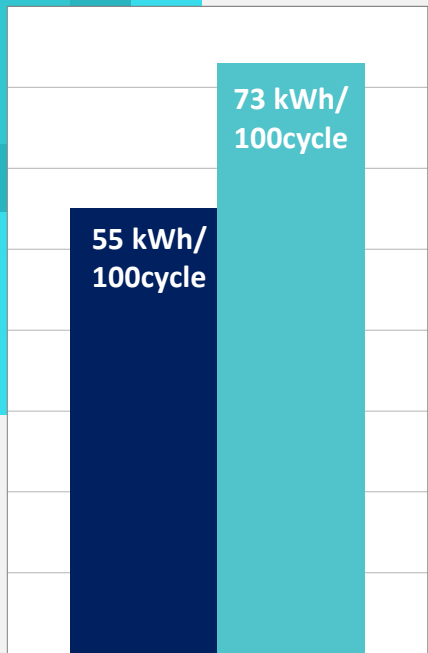

Energy Consumption

■ PYROJET 8 KG
(B)

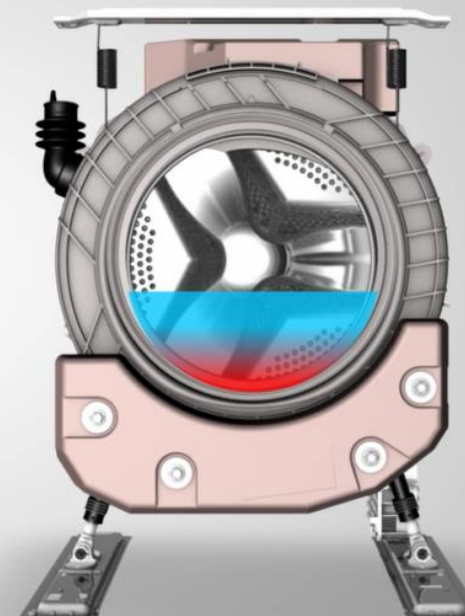
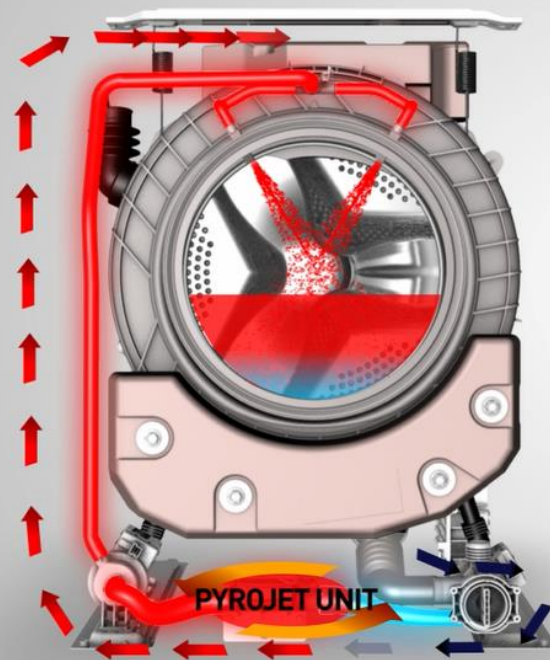

Меньше потребления воды и электроэнергии
Короткое время программ

VESTEL

 **Standard
Drum**



 **Pearl
Drum**



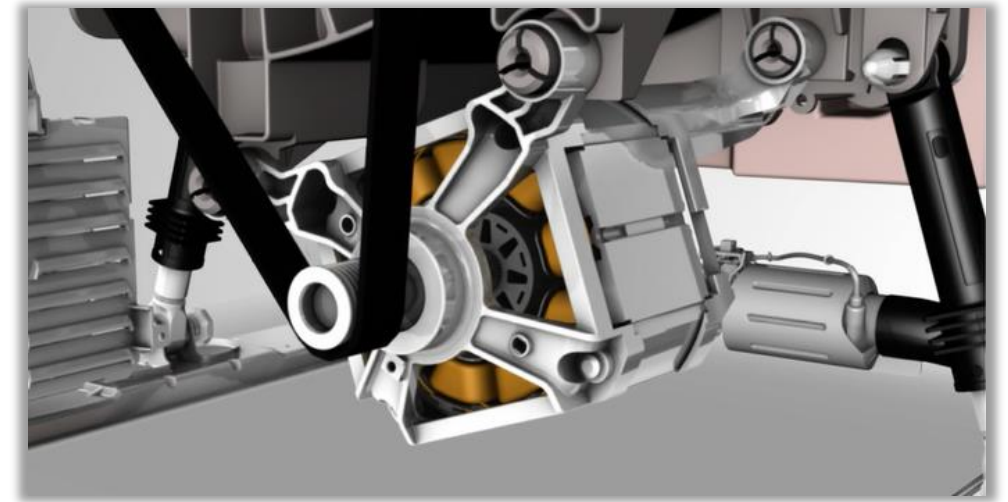
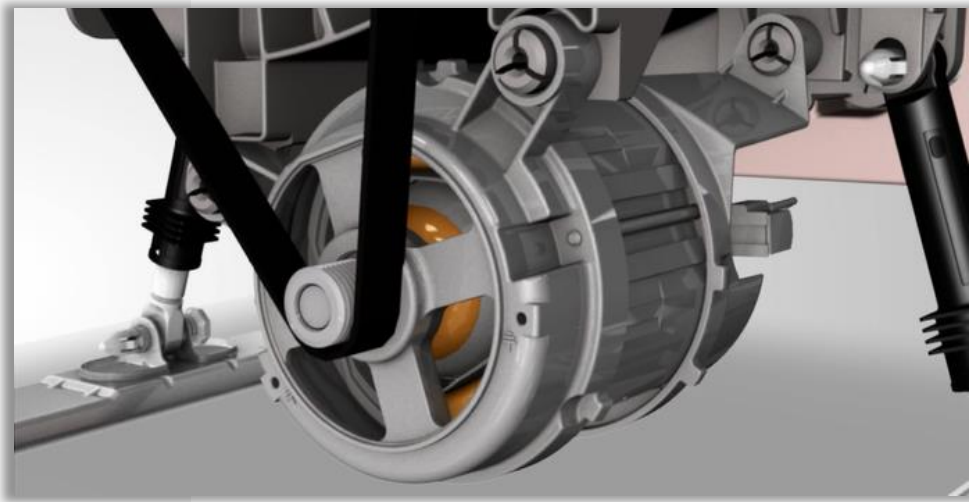

- Стандартный тип
- Высокие обороты для DC мотора

- Высокая эффективность
- Больше загрузка – высокий крутящий момент
- Повышенная надежность
- Меньше шума
- Дольше срок службы

Виды
моторов

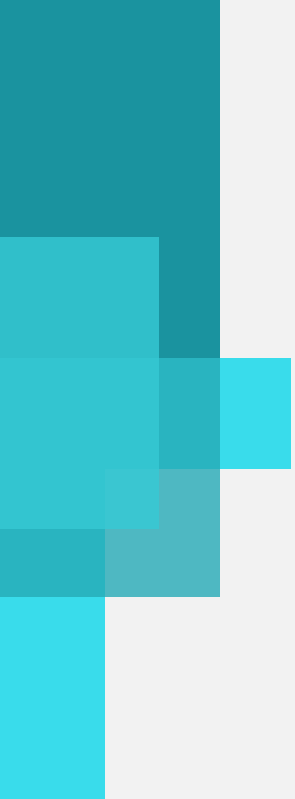

Надежная гигиена



Свежее белье



Меньше помятостей



 **Perfect
Anti-Crease**

 **Advanced
Hygiene**

 **Refresh
29 min.**

 **Drum
Extra Clean**

**Steam
Generator**

VESTEL

Сушильные машины





Power Dry Technology



Конденсационная 7-8-9 kg

Быстрые

- Shirts 12'
- Express 29'

Специальные

- Delicate
- Baby
- Duvet
- Spor

Ежедневные

- Refresh
- Wool Refresh
- Mix
- Jeans



Heat Pump Technology



Тепловой насос 7-8-9 kg

Быстрые программы

- Shirts 30'
- Express 45'

Специальные

- Delicate
- Baby
- Duvet
- Spor

Ежедневные

- Refresh
- Wool Refresh
- Mix
- Jeans

Специальные
программы

VESTEL

Fastest Program

Shirts 12' → 3 футболки за 12 min

Express 29' → 8 футболок за 29 min



2 быстрых программы в одной машине



Специальные
программы

VESTEL

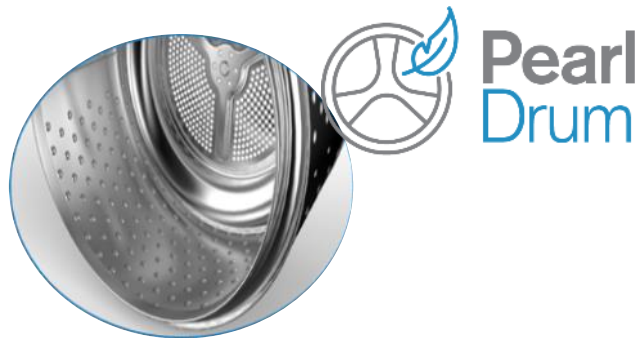

Pearl Drum Design For Gentle Drying



Special Designed Lifter For Less Wrinkle



Special Algorithms For Uniform Drying and Less Crease



AntiCrease

Vestel tumble dryers are designed to have less wrinkled clothes. Thanks to exclusive lifter design, pearl drum figure, specially designed program algorithms and drum movements, garments are dried gently and creasing is minimized.

Забота о
белье

VESTEL

Посудомоечные машины



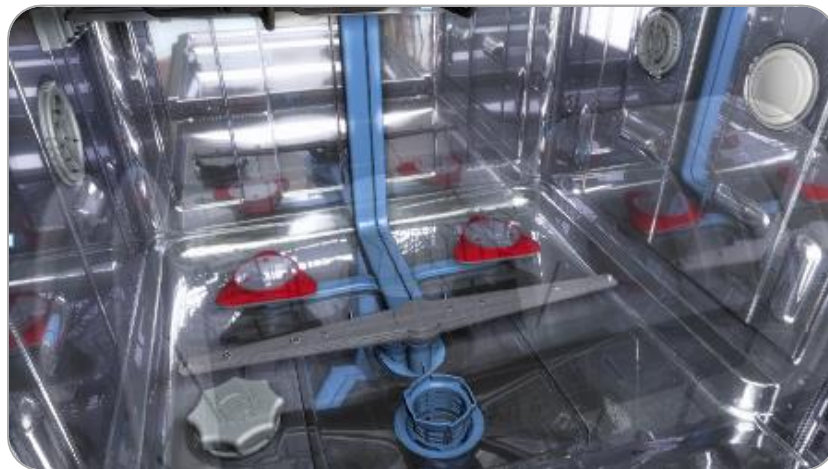

Тройная мойка обеспечивает поистине захватывающую и мощную очистку с помощью двух дополнительных распылителей, которые могут работать как вместе с основным распылителем, так и по отдельности

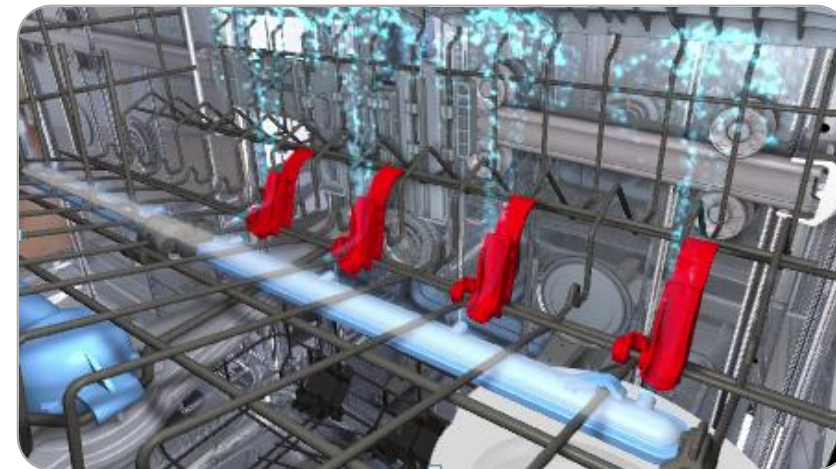

Прямая мойка обеспечивает глубокую и точную разнонаправленную целенаправленную очистку с точностью до мелочей. Распылитель может быть направлен вверх для эффективного мытья стаканов и детских бутылочек или вниз для достижения дополнительной прочности мытья посуды, расположенной ниже.

Ключевые
моменты

VESTEL



Принцип работы технологии Water Box основан на получении промывочной воды последнего цикла очистки, ее фильтрации во избежание попадания каких-либо частиц и хранения в изолированном контейнере. Затем его можно использовать в качестве очищающей воды для цикла предварительной стирки. С помощью этой технологии достигается потребление воды объемом 5,4 л при энергопотреблении А++ в течение 15 часов.

Автоматическая дверь - это технология, которая делает процесс сушки более эффективным. Автоматическая дверца автоматически открывает дверцу посудомоечной машины во время процесса сушки, и таким образом горячий воздух выходит из посудомоечной машины сам по себе, что значительно снижает затраты энергии на сушку посуды. С помощью этой технологии достигается потребление энергии +++ -20% в течение 14 часов.

Ключевые моменты



Уменьшение расхода воды с 12 л до 9 л без использования отводного клапана с помощью запатентованного зубчатого механизма Vestel.



ion-tech содержит электрически заряженный провод, расположенный рядом с дополнительным вентилятором, который распространяет отрицательные ионы внутрь посудомоечной машины. Отрицательные ионы нейтрализуют частицы неприятного запаха и пыли в воздухе. Благодаря удалению частиц из воздуха в посудомоечной машине технология Natural Ion Tech улучшает качество воздуха и устраняет неприятные запахи.

Ключевые
моменты

VESTEL

Antibacterial Filter



Система микрофильтров с антибактериальными свойствами обеспечивает более гигиеничные и экологически чистые продукты с гигиеническим коэффициентом 99,9%.

DualPro Wash



Достигайте идеальной производительности при одновременном мытье различных типов посуды.

Ключевые
моменты

EcoWash



Обеспечивает независимое использование верхней и нижней корзин в рамках вариантов загрузки. Экономит энергию и снижает потребление воды.

Hygienic Wash



Специальная гигиеническая программа обеспечивает максимальную гигиену при мойке на высокой температуре.

Ключевые
моменты

 Quick
Clean



Достижение первоклассной производительности стирки благодаря усовершенствованной программе стирки за 50 минут.

Silent Wash



Двигатель циркуляционного насоса с технологией BLDC. Оптимизированная рама с использованием вибрационного и акустического моделирования.

Ключевые
моменты

VESTEL

infoLED 2.1



Из-за того, что встроенные элементы управления посудомоечной машиной скрыты, трудно определить, завершилась ли программа. Благодаря технологии Info Led легко проверить, запущена ли программа или завершилась.



*When the program finish,
Green Led will glow

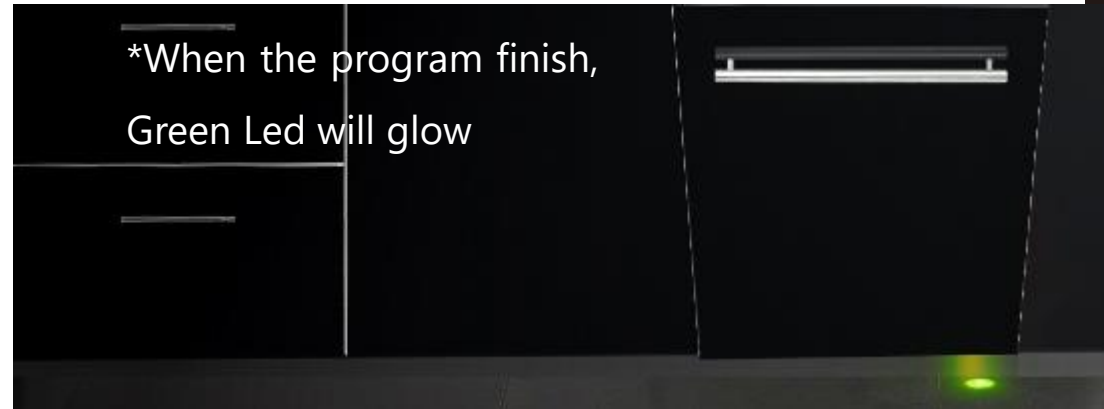

Ключевые
моменты

VESTEL

3 корзина - Опции



EcoTray



EasyTray



ComfortTray

Ключевые
моменты

**Встраиваемая
техника**





- 50lt compact oven platform.
- Same control panel aesthetics with 75 lt BI oven Platform
- Slim Control Panel



Sub types:

- Convection
- Convection with Pyrolytic
- Cleaning Steam Assisted

45CM
COMPACT

60 CM
Двойные
духовые
шкафы



- The new platform will include BI and BU electric cookers.
- Same control panel aesthetics with 75 BI Oven Platform
- Built in double ovens:
 - 73 - 78lt. net main oven cavity volume (with fan)
 - 39-41lt. top oven cavity volume
- Built under double ovens:
 - 48-54lt. net main oven cavity volume (with fan)
 - 39-41lt. top oven cavity volume

Heatwrap технология



- More homogenous cooking in shorter time with less energy consumption
- Cook 4 different meals simultaneously without mixing odours.
- Cook evenly at 5 levels at the same time
- No need to adjust tray position for less than 5 level cooking
- No need to change the position of the trays during cooking



VESTEL



- Creates an air stream and avoids the hot air coming out of the cavity to reach the end user
- Patented

Working principle;

- Hot air shield is located at the cool air exit
- When the oven door is opened, hot air shield is released and speed of the cooling fan increase, then hot air shield redirects the cool air and it creates an curtain that keeps hot air inside the inner cavity.
- When oven door is closed, hot air shield is closed, speed of the fan goes back to regular speed and air continues to cool down the door by going through glass layers.

Монохромная
панель
управления TFT
Controller



- 4.3" TFT LCD display
- Orange, white and red display color options (adjustable from the interface options)
- Touch control
- 50 auto cooking functions
- Manual cooking mode
- Multi language support
- A energy class
- Available with convection and pyrolytic ovens

Ready Cook панель управления

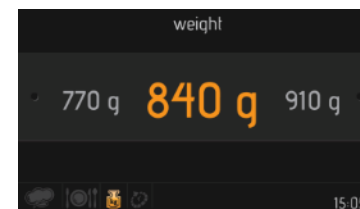

- 4.3" TFT LCD display
- Knob control
- 150+ auto cooking functions
- Manual cooking mode
- 10 favorite function storage
- Can create & store favorite cooking functions
- Multi language support
- WIFI option, part of Vestel smart product family
- 65lt. & 75lt. Platforms
- Available with convection, pyrolytic and steam assisted ovens

Функция ПАР



- 65 & 75 lt. Built In Oven Platform
- Steam assisted cooking functions
- PIPO water storage tank and steam generator
- Ready Cook controller
- Steam cleaning auto functions and steam in manual mode
- Steam clean function (VapClean+)



Самые тихие духовые шкафы



Slim Touch LED



Visio Touch



Full Touch LED

- 65 & 75 lt. Built In Oven Platform
- Previous record is 41 dBA in multifunction
- Vestel has achieved 35dB(A) sound power
- Will available with Full Touch Led Control and Visio Touch, Led Slim Touch Control Panels.

LED Slim Touch
панель
управления



- Touch Control Direct Selection Oven Functions
- Touch Control Direct Selection
- Cooking Functions
 - Bread and Pastry, Meat, Poultry, Pizza
 - Yoghurt, Slow Cooking, Defrosting



Индукционные панели с Multi slider управлением

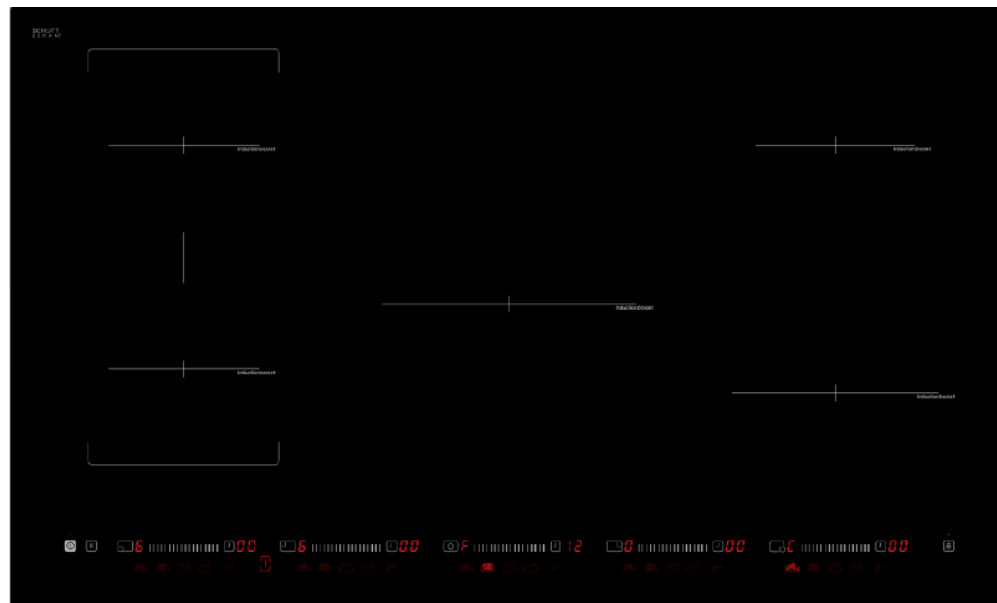

- 90cm Vestel Series I induction hob platform.
- 1 bridge and 5 independent cooking zones.
- Slider TC for each zone.
- Single on/off, Key Lock, timer and Pause Function button for all zones.
- Illuminated LED touch buttons for Cooking Mode.

60
Индукционные
панели с
зоной Double
Bridgezone

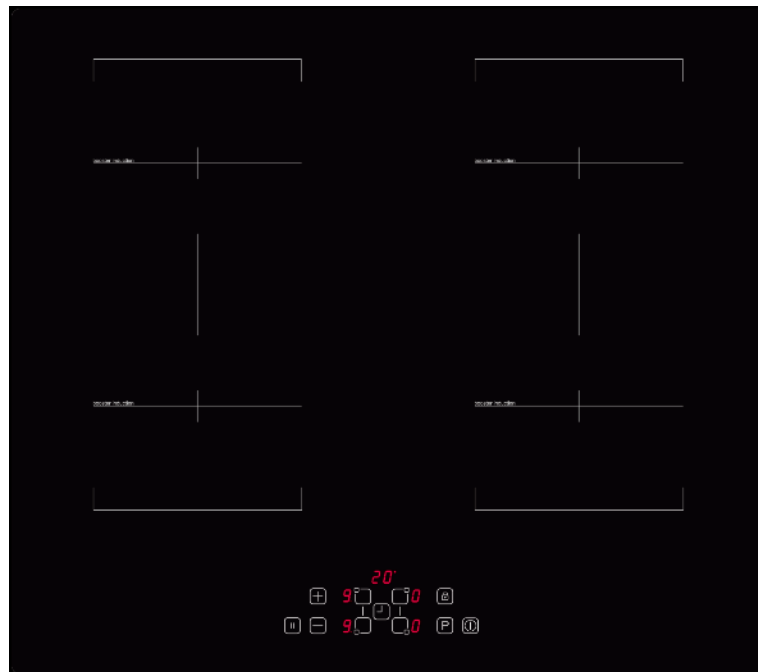

- 60 cm Vestel Series II induction hob platform
- 2 Bridge (4x160) cooking zones
- Front /Slider Touch Control Options
- Timer
- Cooking Mode Function

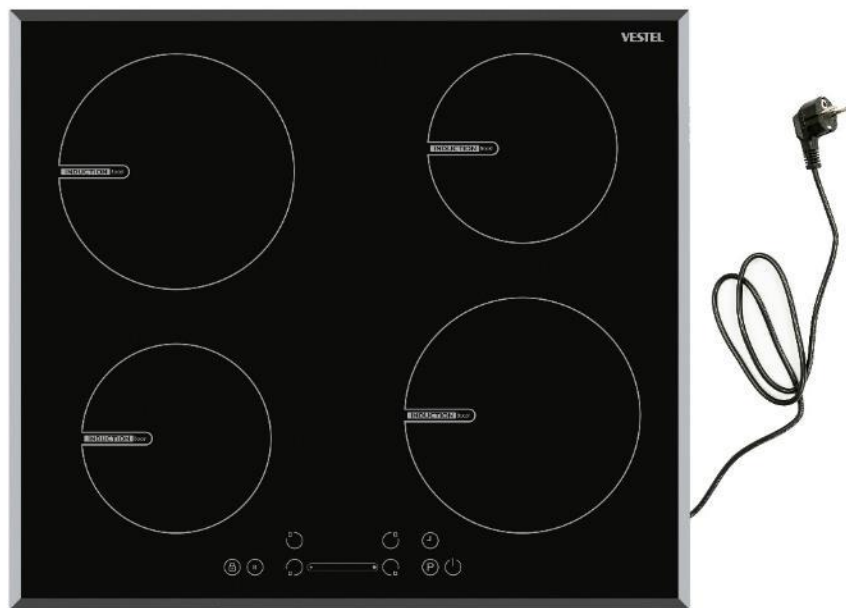

- 60 cm induction hob with power management
- Easy installation with plug
- EU/ UK/ AU/Cable without plug alternatives
- Product comes with requested current value
- Timer
- Key lock / Child lock / Smart Pause
- Thermal cut-off system / Auto-off
- Optional slider touch control
- 2 x 160 mm, 1.4 kW /Booster 1.8kW
- 2 x 210 mm, 2.1 kW /Booster 2.5kW

Current(A)	Max Power(W)
13A	2900W
15A	3500W
16A	3600W
32A	7400W

Индукционные
панели с вилкой
подключения

Стеклянная газовая панель



- 65cm and 70cm front knob controlled gas on glass hob with Defendi semi-flat burners
- 20% less energy consumption
- 5kW Wok Burner (optional for 60cm)
- R: 3kw, S: 1,75kW, A: 1kW
- Cast iron pan support
- Suitable for LPG and NG
- Installation on 60cm cut-out for both dimensions
- Behind the technology;
- Semi-flat burner structure allows flames to reach directly to the pot with 45° of incline



VESTEL

90 см
Профессиональные
плиты



- Knob control for induction hob zones
- Touch control for induction hob timer

Available with;

- 5 Zones
- Standard Aesthetics (Flat/3D)
- Only Digital Touch Timer

VESTEL

60 см
Отдельностоящие
плиты



- 60 cm freestanding oven,
- 16 A hob power,
- 2x160, 2x210 induction cooking zones,

Линейка систем охлаждения

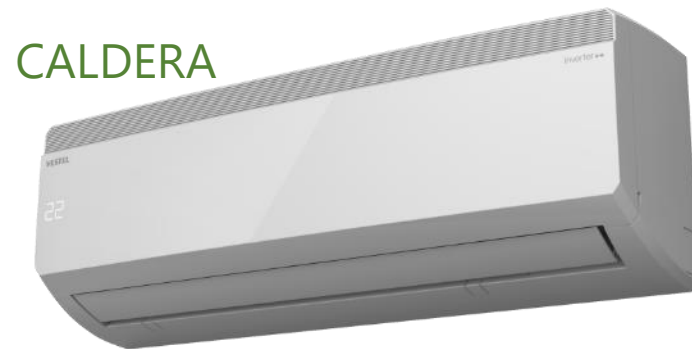

FLORA Platform

DAHLIA Platform

VESTEL

Кондиционеры

